

1

2

3

4

5

6

A

A

B

B

C

C

D

D

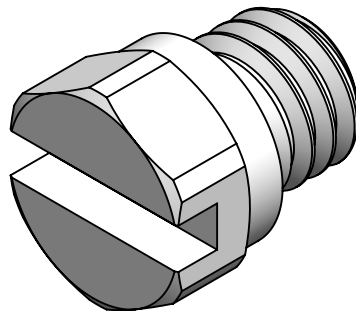
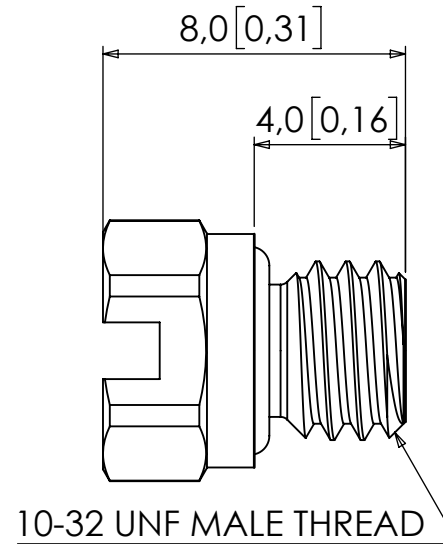
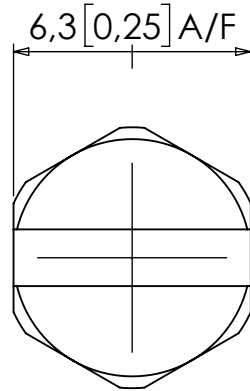

1				30/10/2024	FIRST RELEASE
REV	CREATED	CHECKED	APPROVED	DWG DATE	REVISION SUMMARY

MATERIAL: NICKEL PLATED BRASS, FKM

THIS DRAWING IS CONFIDENTIAL AND IS THE PROPERTY OF THE WEST GROUP LTD AND MAY NOT BE REPRODUCED IN WHOLE OR IN PART, OR USED FOR ANY OTHER PURPOSE OTHER THAN THAT FOR WHICH IT IS SUPPLIED. ALL RIGHTS IN RESPECT OF PATENTS, DESIGN AND COPYRIGHTS RESERVED.



WEST GROUP LTD, UK  
 TEL: +44 (0) 23 9226 6031  
 WWW.WESTGROUP.CO.UK  
 SALES@WESTGROUP.CO.UK

TITLE: NICKEL PLATED BRASS BLANKING PLUG, FKM SEAL, 10-32 UNF MALE THREAD

	DIM'S mm[inch]	SCALE NTS	SIZE A4	SHEET 1 / 1	DOCUMENT NUMBER E-F-1U-PG-NPB-V	REVISION 1
--	-------------------	--------------	------------	----------------	------------------------------------	---------------